

AirAnt

The AirAnt antenna is designed to be mounted on aircrafts* and applications where low profile and aerodynamic shape are desired. The sophisticated interference signal rejection and capability to track GPS, GLONASS and Galileo signals make this antenna useful for wide range of applications.

AirAnt's lightweight yet rugged design combined with low power consumption make it an ideal antenna for almost any environment.

* AirAnt is not FAA (U.S. Federal Aviation Administration) certified yet and cannot be used in commercial aircrafts or any application where FAA certification is required.

AIRANT

Signal	
Capability	L1 GPS/GLONASS/Galileo L2 GPS/GLONASS L5 GPS E5 Galileo
Frequency	1565~1610 MHz 1165~1253 MHz
Electrical	
Antenna Gain	1565~1610 MHz - 5.0 dB typ. 1165~1253 MHz - 4.0 dB typ.
Axial Ratio	3.0 dB max.
Output Impedance	50 Ohm
VSWR	2.0 : 1
LNA gain	30±3 dB
Noise Figure	1565~1610 MHz - 2.5 dB max. 1165~1253 MHz - 2.0 dB max.
DC voltage	4.7~12.0VDC 85mA@5.0V typ.
Environmental	
Operating Temperature	-50°C ~ +85°C
Storage Temperature	-60°C ~ +85°C
Humidity	Waterproof
Mechanical	
Antenna type	Microstrip
Connector	TNC
Weight	320 g
Dimensions	120 mm x 74 mm x 44 mm
Enclosure	Radome: GE PEI+40%GF Base: Aluminum
Color	White
Mounting	4 holes

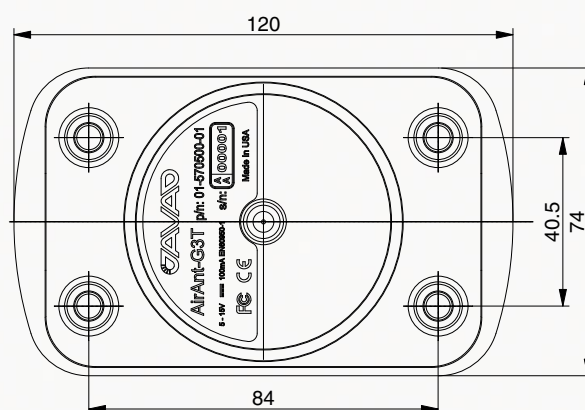
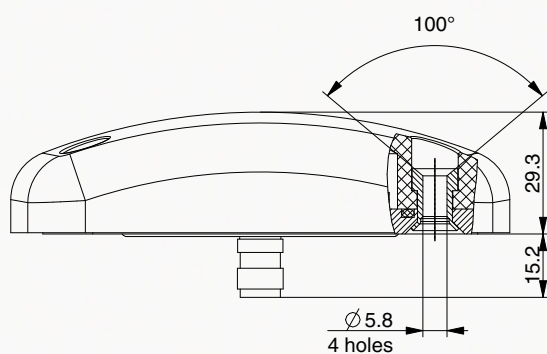

* All dimensions are in mm

Specifications are subject to change without notice.



JAVAD GNSS
www.javad.com

