

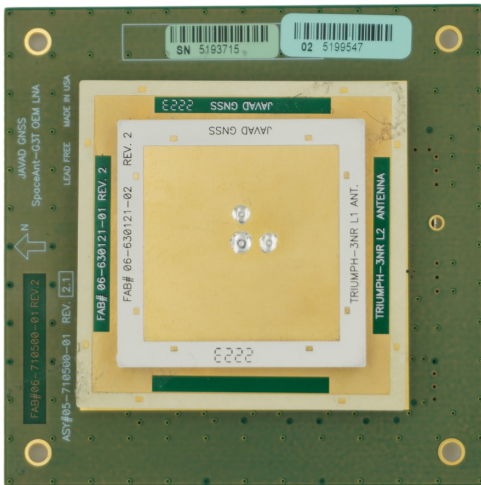

SpaceAnt

OEM GNSS Antenna



Key Features

- All GNSS Constellations
- Extended Operating Temperature
- L-Band Tracking
- Stable Phase Center
- Zenith to Horizon Tracking
- Out-of-Band Rejection

SpaceAnt is a wide-band OEM GNSS antenna designed for reliable signal tracking of GPS, GLONASS, Galileo, BeiDou, NavIC, QZSS, and SBAS frequencies, as well as L-Band. This antenna features a stable phase center with enhanced signal reception and is usable for single, dual, and triple frequency applications. The compact and robust design allows flexibility, performance, and easy integration in the LEO satellite environment.

SpaceAnt complements our space-hardened TR-2S LEO receiver to create a complete OEM solution on small satellites.



GNSS Constellations	Constellation	Channels	Gain*, dB	Channels	Gain*, dB
	GPS	L1	5	L2/L5	4
	GLONASS	L1		L2/L3	
	Galileo	E1		E5A/E5B	
	BeiDou	B1/B1C		B2A/B2B	
	QZSS	L1		L1/L2	
	SBAS	L2		L5	
	NavIC	L2		L5	
	L-Band	1525-1559 MHz			
Out-of-Band Rejection	1165-1254 MHz 1520-1610 MHz	>50 dB @ 1000 MHz, >25 dB @ 1300 MHz >30 dB @ 1400 MHz, >20 dB @ 1462 MHz, >10 dB @ 1480 MHz >10 dB @ 1690 MHz, >30 dB @ 1710 MHz, >45 dB @ 1800 MHz			
Electrical	Axial Ratio Output	3.0 dB max.			
	Impedance	50 Ohm			
	VSWR Max	2.0:1			
	LNA Gain	32 ± 2 dB			
	Noise Figure	1.7 dB typical			
	DC Voltage	+3.6 to +5.5 VDC			
Power	External Input	Power Consumption			
	Input Voltage	+4.5 to +40 VDC			
	Power Consumption	2.2 W typical			
Physical	Dimensions	70.1 mm x 70.1 mm x 16.6 mm			
	Weight	62 g			
Environmental	Operating Temperature	-45°C to +85° C			
	Storage Temperature	-50°C to +85°C			
	Shock & Vibration	MIL-STD-810H Method 516.8 Functional Procedure I MIL-STD-810H Method 514.8 Procedure I, Category 4			

* Typical at zenith.

Detailed Dimensions & Mounting Points

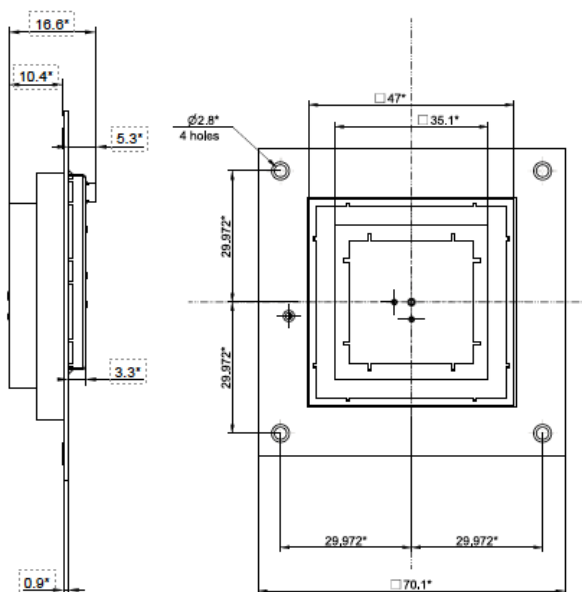

GNSS performance is dependent on signal quality, satellite geometry, ionospheric and tropospheric conditions, baseline length, multipath effects and RF interference. Specifications may be changed without notice.